

Mains connection

3-pole

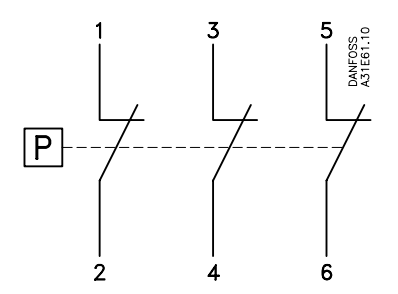

1-pole a.c.

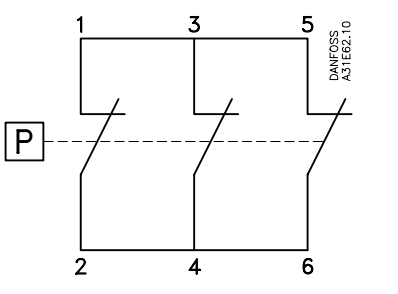

1-pole d.c. load

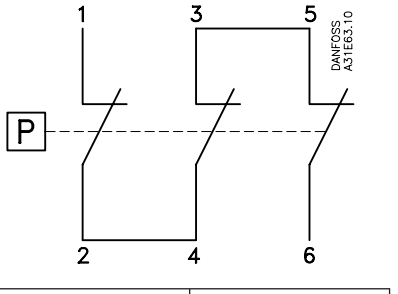

Contact load	AC-3	I_e	U_e
		12 A	220 V * 415 V
	9 A	600 V	
	DC-13/14	2 A	220 V (3 contacts in series)

Dimensions

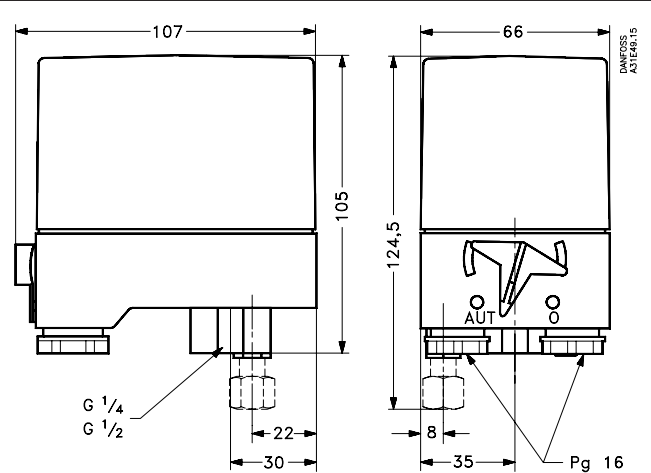

Weight approx. 0.5 kg

Danfoss can accept no responsibility for possible errors in catalogues, brochures and other printed material. Danfoss reserves the right to alter its products without notice. This also applies to products already on order provided that such alterations can be made without subsequential changes being necessary in specifications already agreed. All trademarks in this material are property of the respective companies. Danfoss and the Danfoss logotype are trademarks of Danfoss A/S. All rights reserved.